

## NTF-25

### MAIN FEATURES

- Tray forming up to 25 trays per minute
- 2-axis servo motion: glue application (or transfer), and forming head motion
- Active tray magazine, reload on the fly
- Flexible forming funnel design, accommodates material variance/imperfections
- Tool-less changeover - generally less than 5 minutes
- Smallest industry footprint
- Stainless steel frame STANDARD
- Washdown available

# NTF-25 SERVO TRAY FORMER

• Compact • Ergonomic • Intelligent

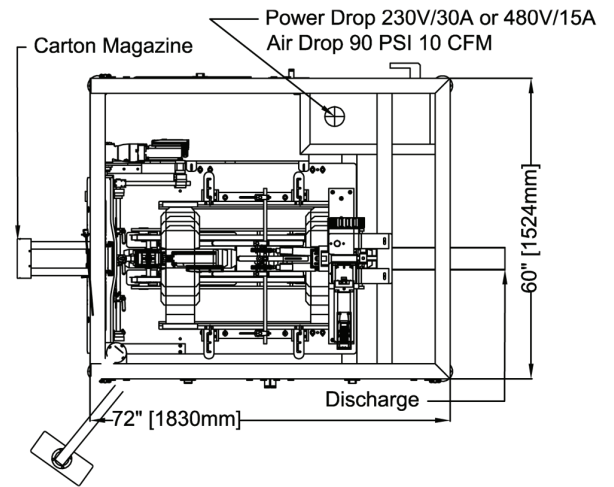
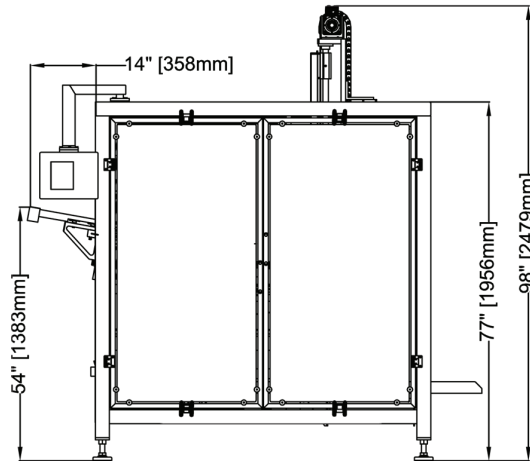

## SPECIFICATIONS:

|                            |  |
|----------------------------|--|
| DRIVE:                     | Servo-driven   |
| SPEED:                     | Up to 25 trays per minute single head  |
| PRODUCT SIZE RANGE:        | Per Project Specification  |
| TRAY SIZE RANGE:           | Per Project Specification  |
| BLANK FEED:                | Positively placing tray blanks into servo driven flights. Pneumatic Tray Feeder with vacuum to remove tray blanks from the magazine (servo optional) |
| WEIGHT:                    | Approximately 500kg.   |
| MAGAZINE CAPACITY:         | 1 ft. (~700 blanks)  |
| FRAME:                     | Stainless Steel construction   |
| GUARDING:                  | Anodized Aluminum/ stainless steel and fully accessible polycarbonate interlocked guarding with adjustable feet or casters                           |
| FINISH:                    | All parts in contact with product are stainless steel, anodized aluminum or plastic  |
| CONTROLS:                  | Omron, Schneider Electric, Allen Bradley, with Touch screen HMI  |
| INSTALLATION REQUIREMENTS: | Power: 240 VAC/30 Amps. 3 phase, 50/60 Hz<br>Air: 90 PSI, 10 cfm   |



1111 Flint Road, Unit 29, Toronto  
Ontario, Canada, M3J 3C7  
Tel: (416) 663 7071  
www.nuspark.com

**Distributed by**